



DE

Das neueste Segment in unserem Angebot. Wir sind einer der wenigen Hersteller, der dieses Segment in lackierten und emaillierten Ausführungen anbietet.

Das Rauchrohr dient der Ableitung der Verbrennungs Gase aus dem Pelletofen oder dem Pelletkamin in den Schornstein. Dieses kann auch als Frischluftzuleitung in die Ofen- oder Kaminbrennkammer verwendet werden. Durch die im Kupplungsende vorgesehene Silikondichtung sind die Rauchrohre auch für die Überdruck-Installation (P1) mit einer Wärmebeständigkeit von 200 °C geeignet. Sie können auch in einem in Unterdruck stehenden (N1) Schornsteinsystem verwendet werden, wobei es notwendig ist, die Silikondichtung im Kupplungsende zu entfernen. Damit wird eine Wärmewiderstand von 400 °C erreicht.

ENG

The latest segment in our selection. We are one of the rare manufacturers to offer this segment in colour and enamel.

The purpose of flue elements is to transport the combustion products from the pellet stove or fireplace into the chimney. The elements can also be applied for the inlet of fresh air to the stove or fireplace furnace. Because of the silicone seal built into the connecting end, the flue pipes can be used for positive-pressure installation (P1) with thermal resistance of 200 °C. They can also be used in a negative pressure (N1) flue system, whereby the silicone seal must be removed from the connecting end. This achieves the thermal resistance of 400 °C.

FRA

Toute dernière innovation dans notre gamme de produits. Nous sommes l'un des rares fabricants à proposer ce type de produit en version peinte et émaillée.

Ces tuyaux de fumée sont conçus pour évacuer les produits de combustion du poêle ou de la cheminée à granulé de bois. Ils sont destinés de même à faire circuler de l'air frais dans le foyer du poêle ou de la cheminée. Grâce à leurs joints en silicone au niveau du tuyau de raccordement, les tuyaux de fumée sont adaptés aux installations en surpression (P1) et résistent à la chaleur jusqu'à 200 °C. Ils peuvent être utilisés pour les installations de poêle à système de sous-tension (N1), auquel cas il faudra retirer le joint en silicone du tuyau de raccordement. Dans ce cas, la résistance à la chaleur s'élève à 400 °C.

1,20 mm



Pelletsrauchrohrprogramm Stahlblech

Program for pellet flue
elements - steel sheet

Tuyaux pour poêle à granulé
– tôle d'acier

CO^LOR



1,20 mm Stahlblech / Steel sheet / Feuille d'acier

● ● Farbe: schwarz und grau / Color: black and gray / Couleur: noir et gris

Rauchrohr / Flue pipe / Tuyau de fumée

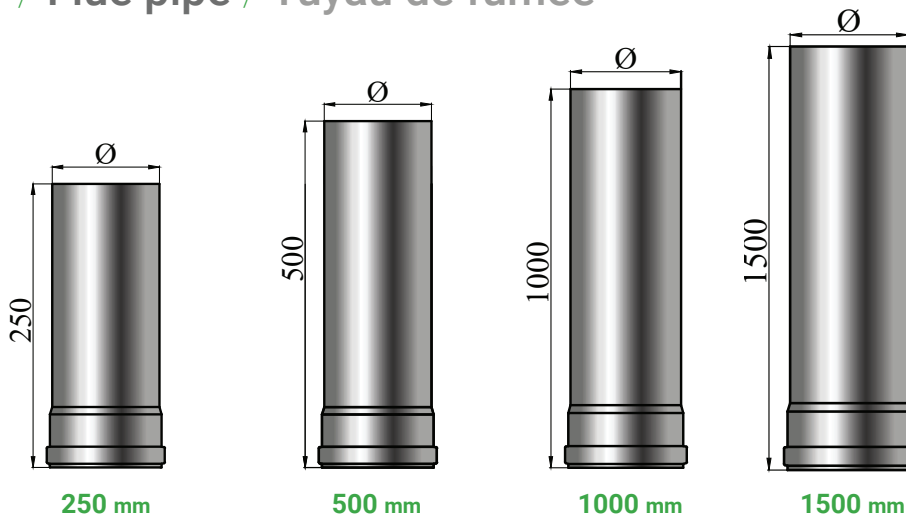

250 mm		
Ø [mm]	CODE ART. NR. N° D'ARTICLE	STÜCK/PAL. PCS./PAL. PIECE./PAL
80	CEP01-080	351
100	CEP01-100	351

500 mm		
Ø [mm]	CODE ART. NR. N° D'ARTICLE	STÜCK/PAL. PCS./PAL. PIECE./PAL
80	CEP02-080	169
100	CEP02-100	169

1000 mm		
Ø [mm]	CODE ART. NR. N° D'ARTICLE	STÜCK/PAL. PCS./PAL. PIECE./PAL
80	CEP03-080	78
100	CEP03-100	78

1500 mm		
Ø [mm]	CODE ART. NR. N° D'ARTICLE	STÜCK/PAL. PCS./PAL. PIECE./PAL
80	CEP04-080	54
100	CEP04-100	54

Erweiterung / Increasing adapter / Extension

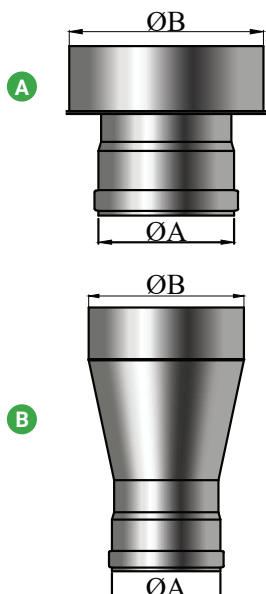

A Gerade / Upright / Plate

Ø [mm]	CODE ART. NR. N° D'ARTICLE	STÜCK/PAL. PCS./PAL. PIECE./PAL
80/130	CEP13-001	280
80/150	CEP13-002	280
100/130	CEP13-003	280
100/150	CEP13-004	280
80/120	CEP13-005	280

B Im Winkel / Inclined / Incliné

Ø [mm]	CODE ART. NR. N° D'ARTICLE	STÜCK/PAL. PCS./PAL. PIECE./PAL
80/130	CEP14-001	288
80/150	CEP14-002	210 (231)
100/120	CEP14-005	280
100/130	CEP14-003	288
100/150	CEP14-004	210 (231)
80/100	CEP14-006	280 (351)



1,20 mm Stahlblech / Steel sheet / Feuille d'acier

Farbe: schwarz und grau / Color: black and gray / Couleur: noir et gris

Zweiteiliges Rauchrohrbogen / 2-part elbow / Tuyau coudé à deux pièces

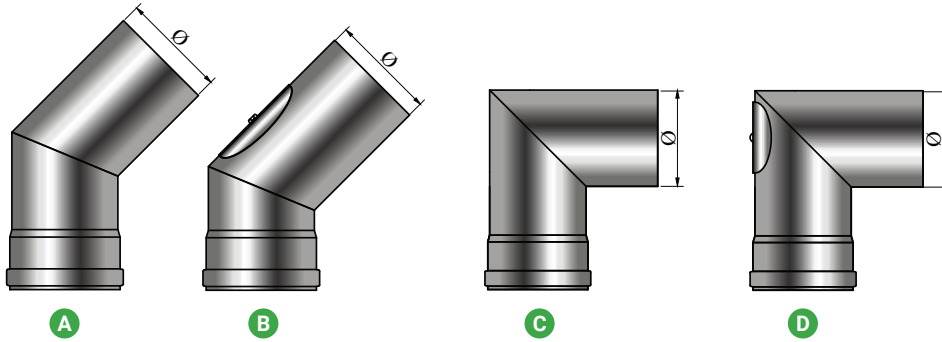

A 45°

Ø [mm]	CODE ART. NR. N° D'ARTICLE	STÜCK/PAL. PCS./PAL. PIECE./PAL
80	CEP05-080	180
100	CEP05-100	180

B 45°
Mit Reinigungsöffnung / With door / Avec porte

Ø [mm]	CODE ART. NR. N° D'ARTICLE	STÜCK/PAL. PCS./PAL. PIECE./PAL
80	CEP16-080	180
100	CEP16-100	180

C 90°

Ø [mm]	CODE ART. NR. N° D'ARTICLE	STÜCK/PAL. PCS./PAL. PIECE./PAL
80	CEP08-080	180
100	CEP08-100	180

D 90°
Mit Reinigungsöffnung / With door / Avec porte

Ø [mm]	CODE ART. NR. N° D'ARTICLE	STÜCK/PAL. PCS./PAL. PIECE./PAL
80	CEP09-080	180
100	CEP09-100	180

Dreiteiliger Rauchrohrbogen / 3-part elbow / Tuyau coudé à trois pièces

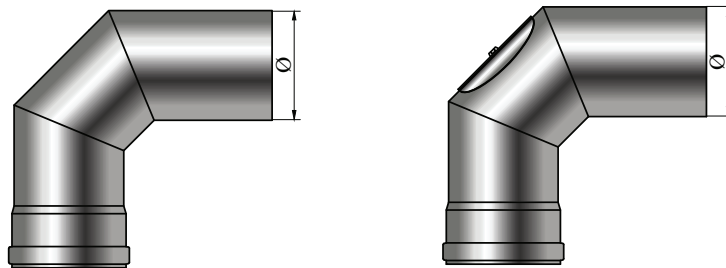

90°

Ø [mm]	CODE ART. NR. N° D'ARTICLE	STÜCK/PAL. PCS./PAL. PIECE./PAL
80	CEP06-080	180
100	CEP06-100	162

90°
Mit Reinigungsöffnung / With door / Avec porte

Ø [mm]	CODE ART. NR. N° D'ARTICLE	STÜCK/PAL. PCS./PAL. PIECE./PAL
80	CEP07-080	180
100	CEP07-100	162



1,20 mm Stahlblech / Steel sheet / Feuille d'acier

● ● Farbe: schwarz und grau / Color: black and gray / Couleur: noir et gris

T-Stück / Tee / Té

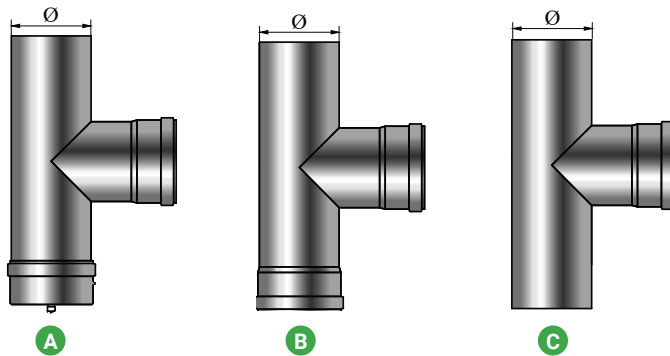

A Mit Kondenzkapsel /
With condensate cover /
Avec couvercle pour condensat

B F/F / F/F / F/F

C

Ø [mm]	CODE ART. NR. N° D'ARTICLE	STÜCK/PAL. PCS./PAL. PIECE./PAL
80	CEP10-080	144
100	CEP10-100	135

Ø [mm]	CODE ART. NR. N° D'ARTICLE	STÜCK/PAL. PCS./PAL. PIECE./PAL
80	CEP15-080	144
100	CEP15-100	135

Ø [mm]	CODE ART. NR. N° D'ARTICLE	STÜCK/PAL. PCS./PAL. PIECE./PAL
80	CEP17-080	144
100	CEP17-100	135

Mauermuffe, doppelt / Twin wall sleeve / Bague murale double

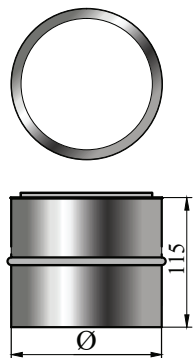

Ø [mm]	CODE ART. NR. N° D'ARTICLE	STÜCK/PAL. PCS./PAL. PIECE./PAL
80	CEP12-080	280
100	CEP12-100	280

Reinigungsklappe mit Riegel / Cover plate with bolt / Couvercle avec loquet

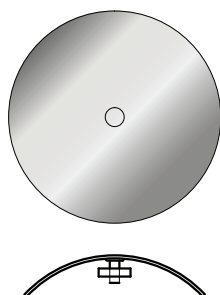



Ø [mm]	CODE ART. NR. N° D'ARTICLE	STÜCK/PAL. PCS./PAL. PIECE./PAL
80	CEP23-080	480
100	CEP23-100	480

 **1,20 mm** Stahlblech / Steel sheet / Feuille d'acier

● ● Farbe: schwarz und grau / Color: black and gray / Couleur: noir et gris

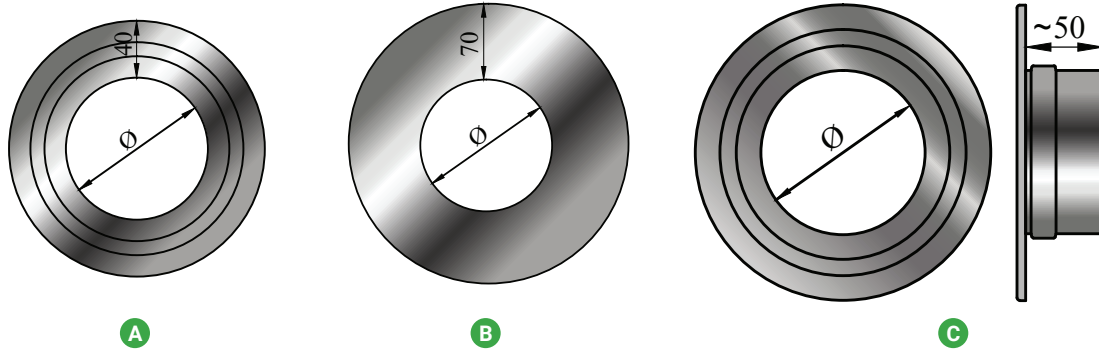

▶ **Rosette / Rosette collar / Rosace**

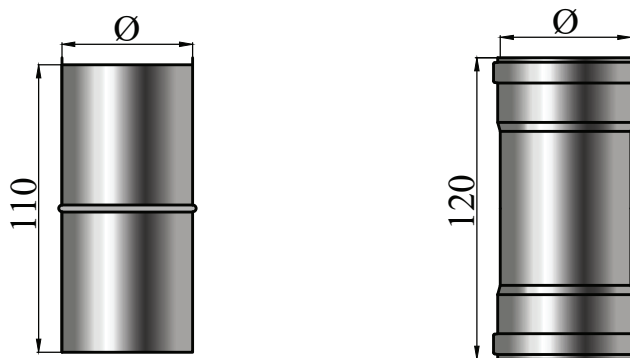

A			B		C		
			7 cm		Mit integrierte Mauermuffe / With wall socket / Avec rosace murale		
Ø [mm]	CODE ART. NR. N° D'ARTICLE		Ø [mm]	CODE ART. NR. N° D'ARTICLE	Ø [mm]	CODE ART. NR. N° D'ARTICLE	 STÜCK/PAL. PCS./PAL. PIECE/PAL
80	CEP11-080		80	CEP32-080	80	CEP24-080	48
100	CEP11-100		100	CEP32-100	100	CEP24-100	48

▶ **Rauchrohr / Flue pipe / Tuyau de fumée**



M/M			F/F		
Ø [mm]	CODE ART. NR. N° D'ARTICLE	 STÜCK/PAL. PCS./PAL. PIECE/PAL	Ø [mm]	CODE ART. NR. N° D'ARTICLE	 STÜCK/PAL. PCS./PAL. PIECE/PAL
80	CEP22-080	280	80	CEP21-080	280
100	CEP22-100	280	100	CEP21-100	280



1,20 mm Stahlblech / Steel sheet / Feuille d'acier

● ● Farbe: schwarz und grau / Color: black and gray / Couleur: noir et gris

Kondenskapsel / Condensate cover / Couvercle pour condensats

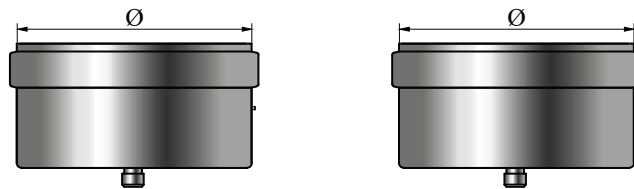

			Mit Ausgang aus Messing / With brass outlet / Raccord en laiton		
Ø [mm]	CODE ART. NR. N° D'ARTICLE	STÜCK/PAL. PCS./PAL. PIECE./PAL	Ø [mm]	CODE ART. NR. N° D'ARTICLE	STÜCK/PAL. PCS./PAL. PIECE./PAL
80	CEP18-080	280	80	CEP19-080	480
100	CEP18-100	280	100	CEP19-100	480

Deckenrosette / Ceiling rosette collar / Rosace de plafond

Mit Dichtung und Schrauben Set / With gasket, screw and wall plug / Avec joint, vis et chevilles

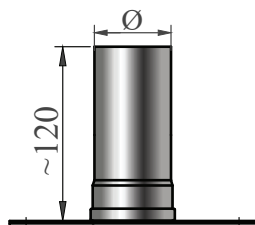
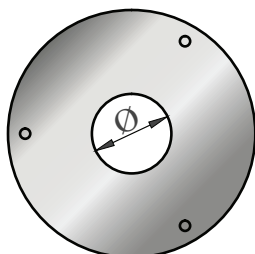

Ø [mm]	CODE ART. NR. N° D'ARTICLE	STÜCK/PAL. PCS./PAL. PIECE./PAL
80	CEP25-080	97
100	CEP25-100	97

Verstellbare Rohrestütze / Adjustable base support for pipe / Base ajustable pour tuyau

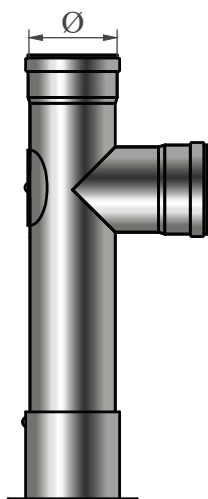

Ø [mm]	CODE ART. NR. N° D'ARTICLE	STÜCK/PAL. PCS./PAL. PIECE./PAL
80	CEP26-080	105
100	CEP26-100	72

● ● Farbe: schwarz und grau / Color: black and gray / Couleur: noir et gris

Hitzeschutz, doppelt / Twin wall heat shield / Double isolation thermique

A B Geeignet für Abstand zu brennbaren Baustoffen bis zu 200 mm / Suitable for use at a distance of up to 200 mm from flammable building materials / Adapté aux matériaux de construction combustibles à une distance 200 mm

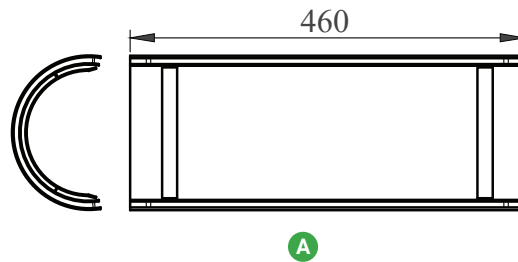

A

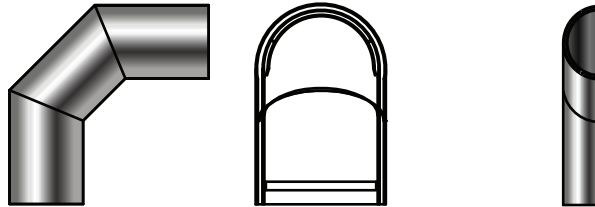

B

C

A Für Rohr / For pipe / Pour tuyau

Ø [mm]	CODE ART. NR. N° D'ARTICLE	STÜCK/PAL. PCS./PAL. PIECE./PAL
80	CEP28-080	105
100	CEP28-100	105

B Für 3-teiligen Bogen 90° / For 3-part elbow 90° / Pour coude à trois pièces 90°

Ø [mm]	CODE ART. NR. N° D'ARTICLE	STÜCK/PAL. PCS./PAL. PIECE./PAL
80	CEP29-080	85
100	CEP29-100	85

C Für bogen 90° seitlich / For elbow 90° lateral / Paroi pour coude de 90° latéral

Ø [mm]	CODE ART. NR. N° D'ARTICLE	STÜCK/PAL. PCS./PAL. PIECE./PAL
80	CEP30-080	85
100	CEP30-100	85



1,20 mm Stahlblech / Steel sheet / Feuille d'acier

● ● Farbe: schwarz und grau / Color: black and gray / Couleur: noir et gris

S-Rohr / S pipe / Tuyau en S

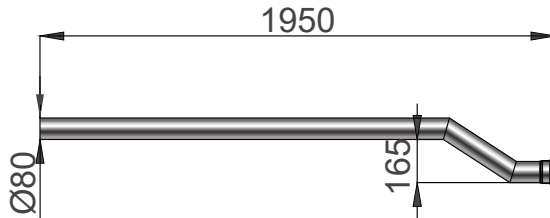

Ø [mm]	CODE ART. NR. N° D'ARTICLE
80	CEP27-080

Teleskoprohr 330 / Telescopic pipe 330 / Tuyau télescopique 330

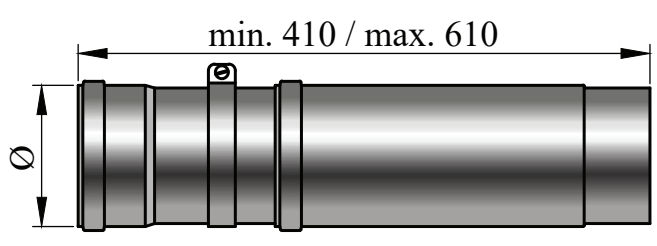

Ø [mm]	CODE ART. NR. N° D'ARTICLE	 STÜCK/PAL. PCS./PAL. PIECE/PAL
80	CEP31-080	175
100	CEP31-100	120

Rohrschelle / Clamp / Collier

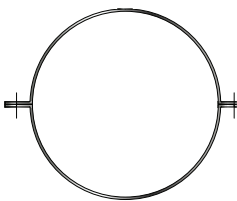

Ø [mm]	CODE ART. NR. N° D'ARTICLE	 STÜCK/PAL. PCS./PAL. PIECE/PAL
80	CEP20-080	480
100	CEP20-100	180

Rohrschelle + 2x Gewindestage M8x100, 1 x Stockschraube M8x100 (M8x50 + 50mm für Holz), 2x Schraubenmutter M8x20

Clamp + 2x screw brackets M8x100, 1x Screw M8x50 / 1x screw 50mm, 2x nut M8x20

Collier + 2x ajustable M8x100 / 1x Vis M8x100 (M8x50+50mm pour bois) 2x écrous M8x20



S-Bogen / S elbow / Coude en S

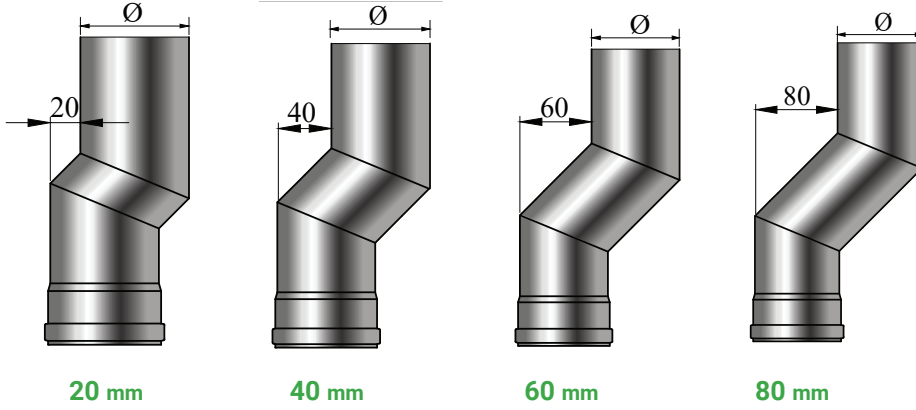

20 mm

Ø [mm]	CODE ART. NR. N° D'ARTICLE	STÜCK/PAL. PCS./PAL. PIECE./PAL
80	CEP33-080	162
100	CEP33-100	162

40 mm

Ø [mm]	CODE ART. NR. N° D'ARTICLE	STÜCK/PAL. PCS./PAL. PIECE./PAL
80	CEP34-080	162
100	CEP34-100	162

60 mm

Ø [mm]	CODE ART. NR. N° D'ARTICLE	STÜCK/PAL. PCS./PAL. PIECE./PAL
80	CEP35-080	162
100	CEP35-100	

80 mm

Ø [mm]	CODE ART. NR. N° D'ARTICLE	STÜCK/PAL. PCS./PAL. PIECE./PAL
80	CEP36-080	175
100	CEP36-100	